

Dual Rail LCD Console

Quick Installation Guide

Rev 1.0

Notes

1. Please check all peripherals according the list before installation. To make sure that the whole unit was not damaged and lost during shipping process. If you encounter any problem, please contact your dealer.
2. Before installation, make sure all peripherals and computers have been turned off.
3. This product required front and rear mounting brackets. Pre-configure the deep of the rack to find the best rear bracket kits for your usage.
4. The standard rear bracket kits are for 420~830 mm as below figure,contact your dealer if you need more longer rear bracket.
5. Reliable earthing of rack-mounted equipment should be maintained. Particular attention should be given to supply connections other than direct connections to the branch circuit.

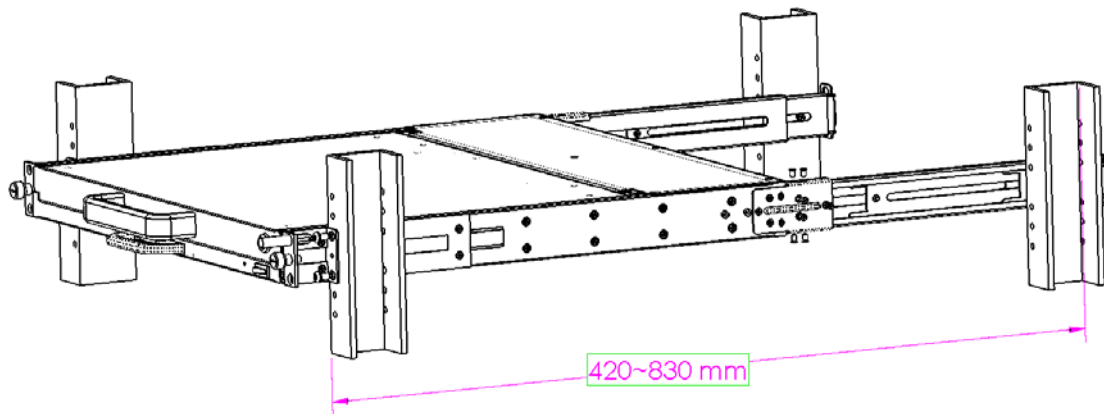

Hardware Kits Contents

Console Packing Content:

1. Short Single Bracket x 2 (For under 520 mm rack depth)

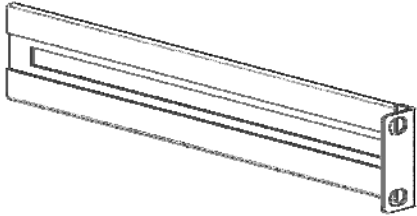

2. Long Assembled Bracket x 2 (For 520 ~ 680 mm rack depth)

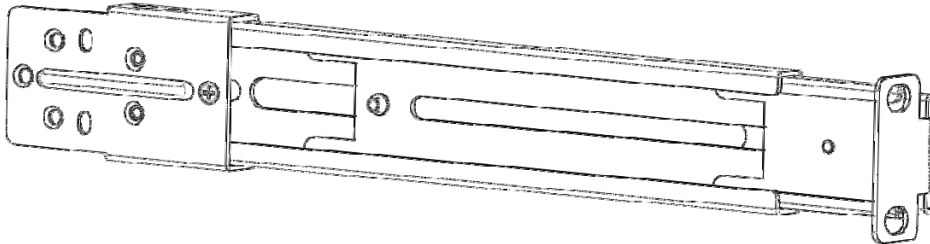

3. Support Bracket x 2 (For 680 ~ 830 mm rack depth)



4. Metal Plate x 2 (For short single bracket)

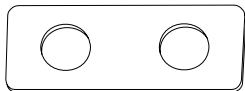

5. Copper Ring x 4 (For short single bracket)



6. Flat Screw x 4 (For short single bracket)



7. Cap Screw x 28



8. Key x 2

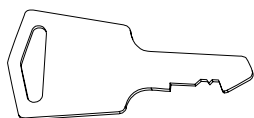

Console with 8 / 16 ports KVM Switch Packing Content:

1. Short Single Bracket x 2 (For under 650 mm rack depth)

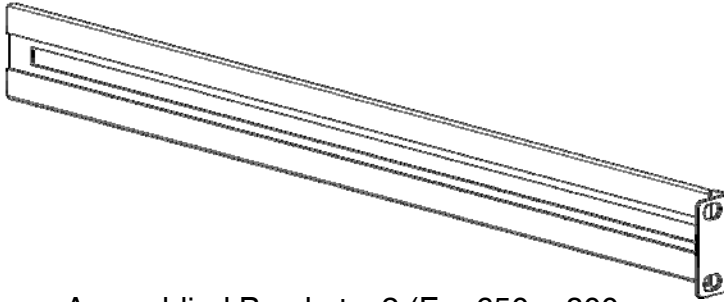

2. Long Assembled Bracket x 2 (For 650 ~ 800 mm rack depth)

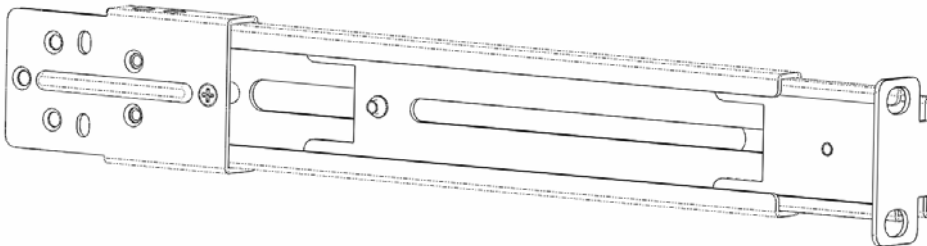

3. Metal Plate x 2 (For short single bracket)



4. Copper Ring x 6 (For short single bracket)



5. Flat Screw x 6 (For short single bracket)



6. Cap Screw x 28

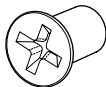

7. Key x 2

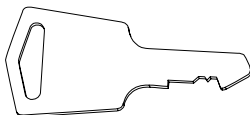

Installation Step



Second person required for rear support during installation

A. Rack Depth Under 520mm

- 1) Release the thumb screw of front bracket. (both side)
- 2) Install front bracket from each side using cabinet screws.

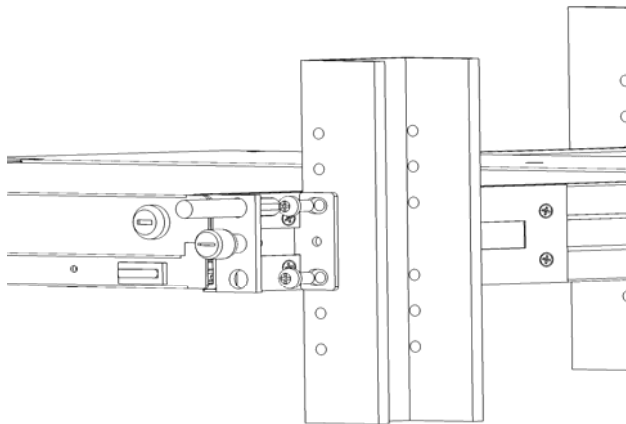

- 3) Install rear bracket from each side.

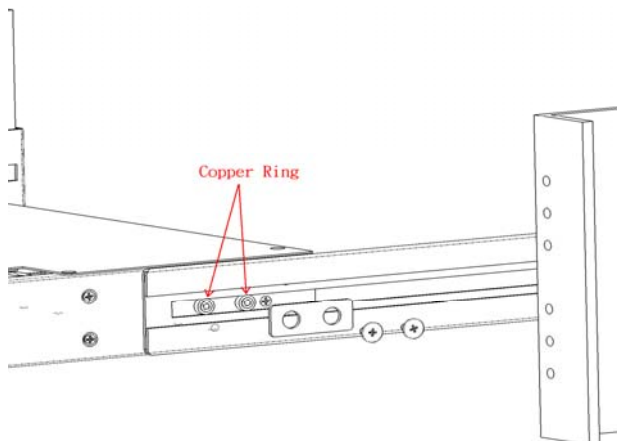

- 4) Install rear bracket from each side using cabinet screws.

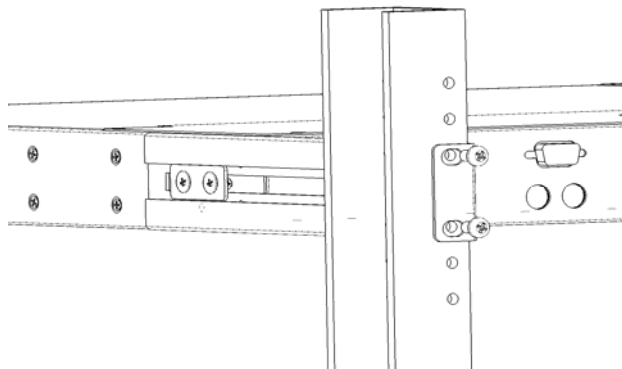

B. Rack Depth Above 520 mm

1. Remove the screw of long assembled bracket and keep screws.

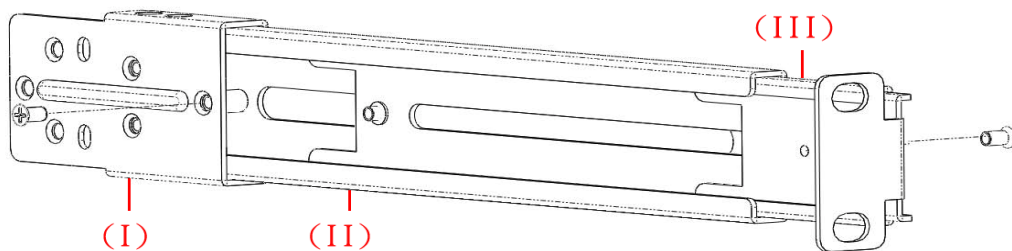

2. Combine (I) to console from each side using cap screw. (5 pcs each side)

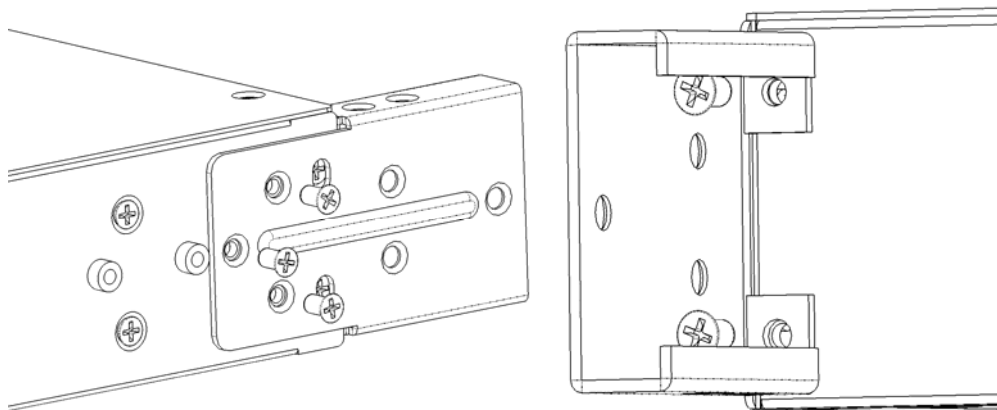

3. Combine (I) and (II) from each side. (7 pcs each side)

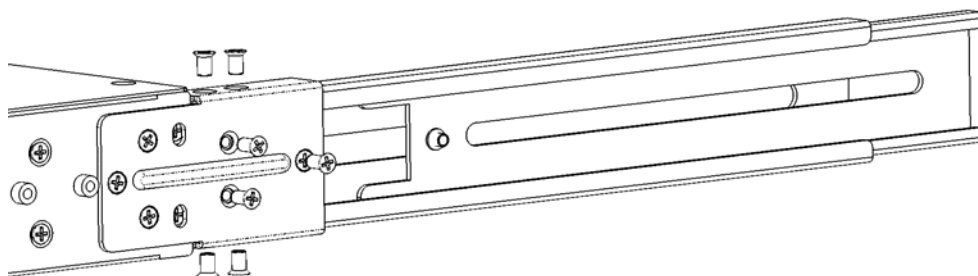

4. Release the Thumb Screw of front bracket and Install front bracket from each side using cabinet screws.

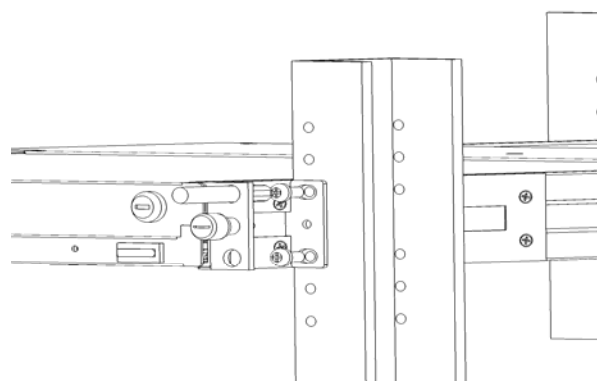

5. Combine (I)+(II) and (III) using the original screw and Install rear bracket from each side using cabinet screws.



Please use support bracket to replace (III) when rack depth is more than 680 mm.

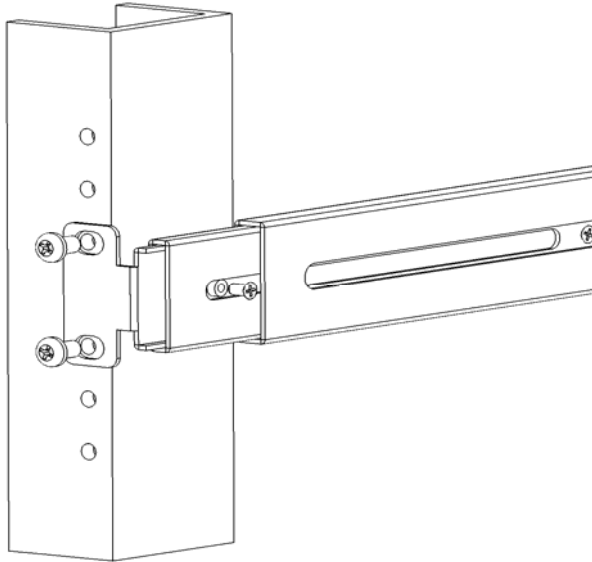

6. Finish Installation as below.

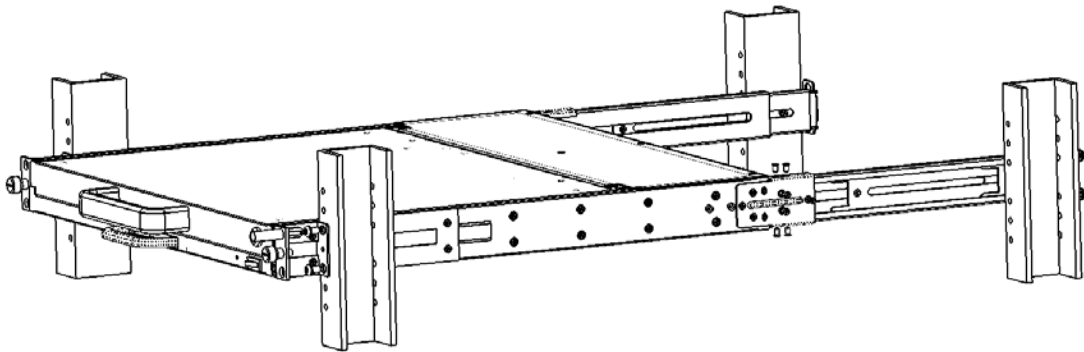

7. Attach provided cable and power cord to use.

Dual Rail LCD Console

Quick Installation Guide